



# HI-FOG® for the food industry

HI-FOG® controls, suppresses and extinguishes fires by using very small amounts of the world's most environmentally friendly fire-fighting agent – water. HI-FOG® is a proven solution with reliability and performance that ensure business downtime due to fire is kept to an absolute minimum.

Using small amounts of pure water, HI-FOG® provides clean, fast-acting fire protection. HI-FOG® water mist penetrates the fire and blocks radiant heat, quickly bringing a fire under control. With proven high performance, HI-FOG® is ideally suited for industrial oil cookers and ovens.

## General

Industrial oil cookers, also known as deep fat fryers, are a unique fire hazard in the food industry. The fire protection system needs to extinguish the flames as well as cool down the oil to prevent re-ignition, without contaminating the oil or the food.

Large, industrial ovens represent a second major fire hazard in the food industry. Here it is the food remnants that may ignite from the excess heat of the ovens. Here, too, the fire protection system

needs to extinguish the flames as well as counter the heat of the ovens.

Compact and light weight, HI-FOG® requires little space for installation. With its low water and power consumption, along with essentially free refills, HI-FOG® is an economical, high performance fire protection system.

HI-FOG® systems for the food industry can have a wide variety of configurations based on project-specific requirements.

## HI-FOG® system for industrial oil cookers

HI-FOG® systems for industrial oil cookers and deep fat fryers are usually configured to provide protection for frying pan, drip plate, air filters, takeout conveyor, and the vertical ducts.

The primary goal is to effectively mitigate damage due to fire and smoke within the protected spaces, as well as minimize water damage from a discharge. The system is typically a deluge type, releasing from all spray heads »

### HI-FOG® fights fire by:

- Cooling
- Radiant heat blocking
- Local oxygen inerting

### HI-FOG® benefits:

- Proven performance
- Low water usage
- Environmentally friendly
- Uses potable water
- Fast acting
- Low water usage



» of each protected section simultaneously when the section valves are opened.

HI-FOG® also has specially designed spray heads to protect ducts. The spray heads are kept protected outside the duct when not in use, preventing clogging of the nozzle openings.

The entire system is served from a single pump unit, which can be electric or diesel driven. The pump size varies depending on the required protection time and size of the protected area.

System discharge can be activated either manually or through a detection system. The detection system consists of heat detectors, flame detectors, along with a control panel.

**HI-FOG® system for industrial ovens**

HI-FOG® systems for industrial ovens are configured to protect the spaces above and below the conveyor. As with oil cookers, the primary goal is to effectively mitigate damage due to fire and smoke within the protected spaces, as well as minimize water damage from a discharge.

The system is designed for automatic or manual activation of the spray heads simultaneously. To comply with NFPA750 standard, the system must have a minimum designed operation time of 30 minutes. However, operation time can be extended as long as there is water and electricity available.

Each system is served by an electric or diesel driven pump unit. The spray heads are mounted both above and below the oven. The system is supplied with a detection system

consisting of heat detectors, flame detectors, along with a control panel.

**FM approved**

With thousands of full-scale fire tests completed, the HI-FOG® Water Mist Fire Protection System is the world's most tested water mist solution.

After fire-tests series supervised by FM, including different length cookers with exhaust hoods both in the lower cooking and upper maintenance positions, Marioff's HI-FOG® system utilizing electric-powered pump is FM approved for the protection of industrial cookers.



HI-FOG® duct protection spray head



HI-FOG® spray head

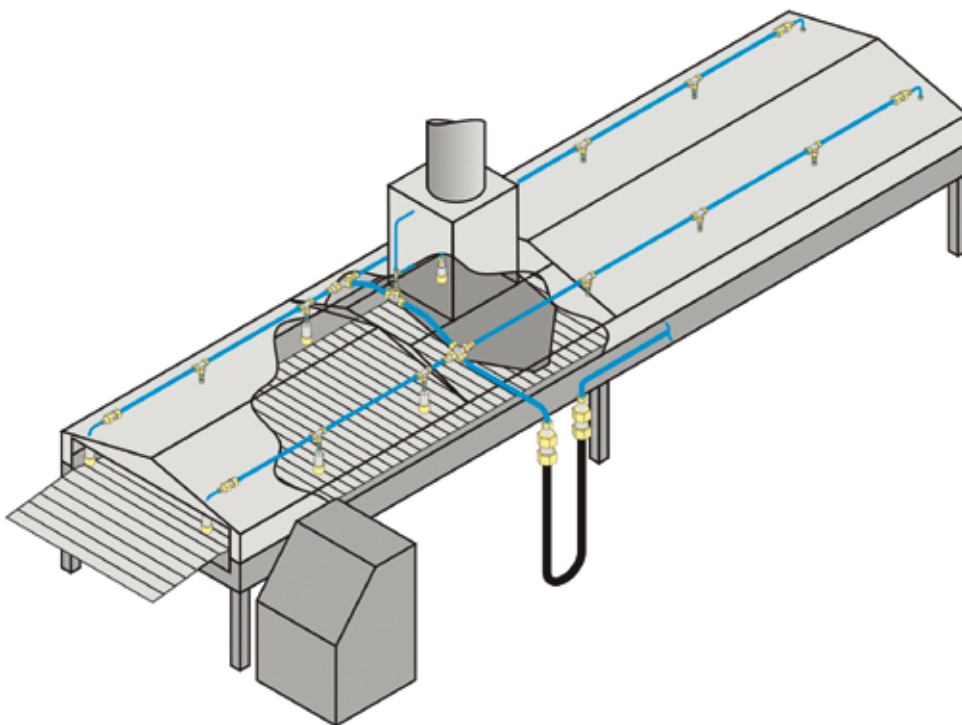

Electric driven pump unit (SPU)

Marioff Corporation Oy  
 PL 86, 01301 Vantaa, Finland  
 Tel: +358 (9) 870 851  
 Fax: +358 (9) 8708 5399  
 Email: info@marioff.fi

Austria • Canada • Finland • France • Germany • Italy • Spain • Sweden • UK • USA

Information on Marioff group companies, agents/distributors and references can be found at [www.marioff.com](http://www.marioff.com).



A UTC Fire & Security Company